

EnergAqua Line

Water Supplied Radiant Heating



Technical Information - EAL

Product Description

Composition

EnergAqua Line, EAL, consists of three parts, the reflective plate, water carrying pipes and insulation. CE marked and manufactured in accordance with EN 14037.

The panel comprises of a 0.6 mm aluminium plate which is cold pressed into optimal shape, the insulation consists of 28 mm thick polyurethane foam. The pipes are made of copper in diameter \varnothing 12 mm. Maximum working pressure 6 Bar.



Design and Function

The surface plate encapsulates the copper pipes maximising the contact surface leading to a highly efficient radiant panel.

The warm water which circulates through the pipes conducts heat to the surface plate, warming the underside of the panel. The increased temperature of the panel enables radiant heat being emitted to cooler surfaces in the room.

Facts and Specifications

Length:	EAL can be made to any length in 100 mm increments from 1000 mm up to 6000 mm per panel.
Width:	400 mm, 800 mm or 1200 mm.
Height:	30 mm.
Number of pipes:	EAL-2 - 2 pcs, copper. EAL-4 - 4 pcs, copper. EAL-6 - 6 pcs, copper.
Connection water:	Horizontal alt. vertical connection.
Link water circuit:	The panels are provided with several different link types; more information on page 4.
Suspension:	Mainly free hanging from the ceiling, but also suitable for surface mounting.
Finish, colour:	NCS0502Y / RAL9010 (White).

Weight

Weight per meter panel, excluding water:

EAL-2	2.6 kg
EAL-4	5.2 kg
EAL-6	7.8 kg

Weight per meter panel, including water:

EAL-2	3.5 kg
EAL-4	7.2 kg
EAL-6	10.8 kg

Construction

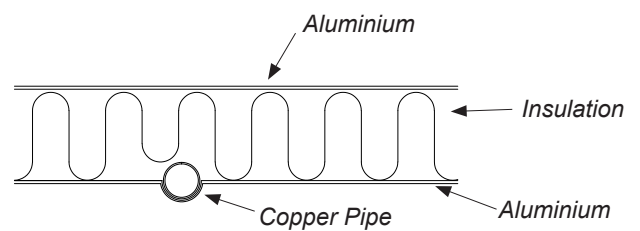

Inter-Connection

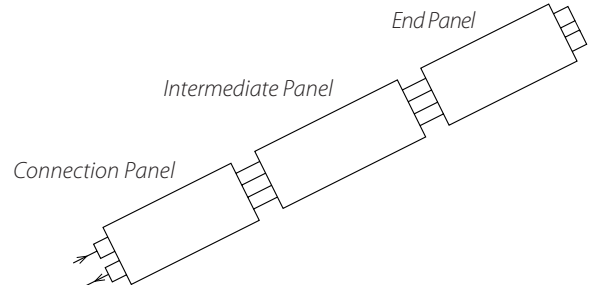

Dimensions

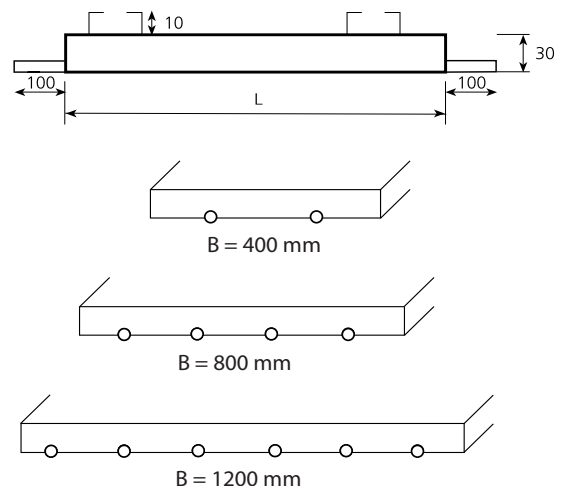

Technical Information

Designations

Pv:	Thermal emission	(W)
qv:	Water flow	(l/s)
Δt_{mv}:	Difference between the mean water temperature and the room temperature	(°C)
tr:	Room temperature	(°C)
Δt_v:	Temperature difference of water	(°C)

Thermal Emission

The heat output, W/m, as result of the difference between the average temperature of the fluid, Δt_{mv} , and the ambient temperature, tr.

Type	Δt_{mv} (°C)					
	20	30	40	50	60	70
EAL-2	76	113	153	193	234	274
EAL-4	152	225	304	384	464	544
EAL-6	228	336	456	576	697	817

Water Flow

Water flow as result of thermal emission, Pv, and temperature difference of water, Δt_v . The water flow should not be lower than recommended to secure turbulent flow in pipes.

Recommended minimum water flow: 0.02 l/s

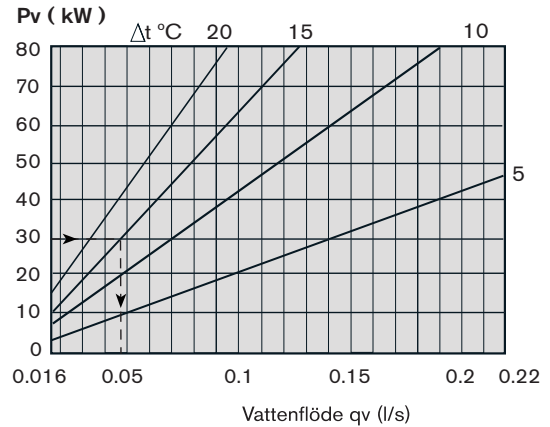

Pressure Drop per Circuit

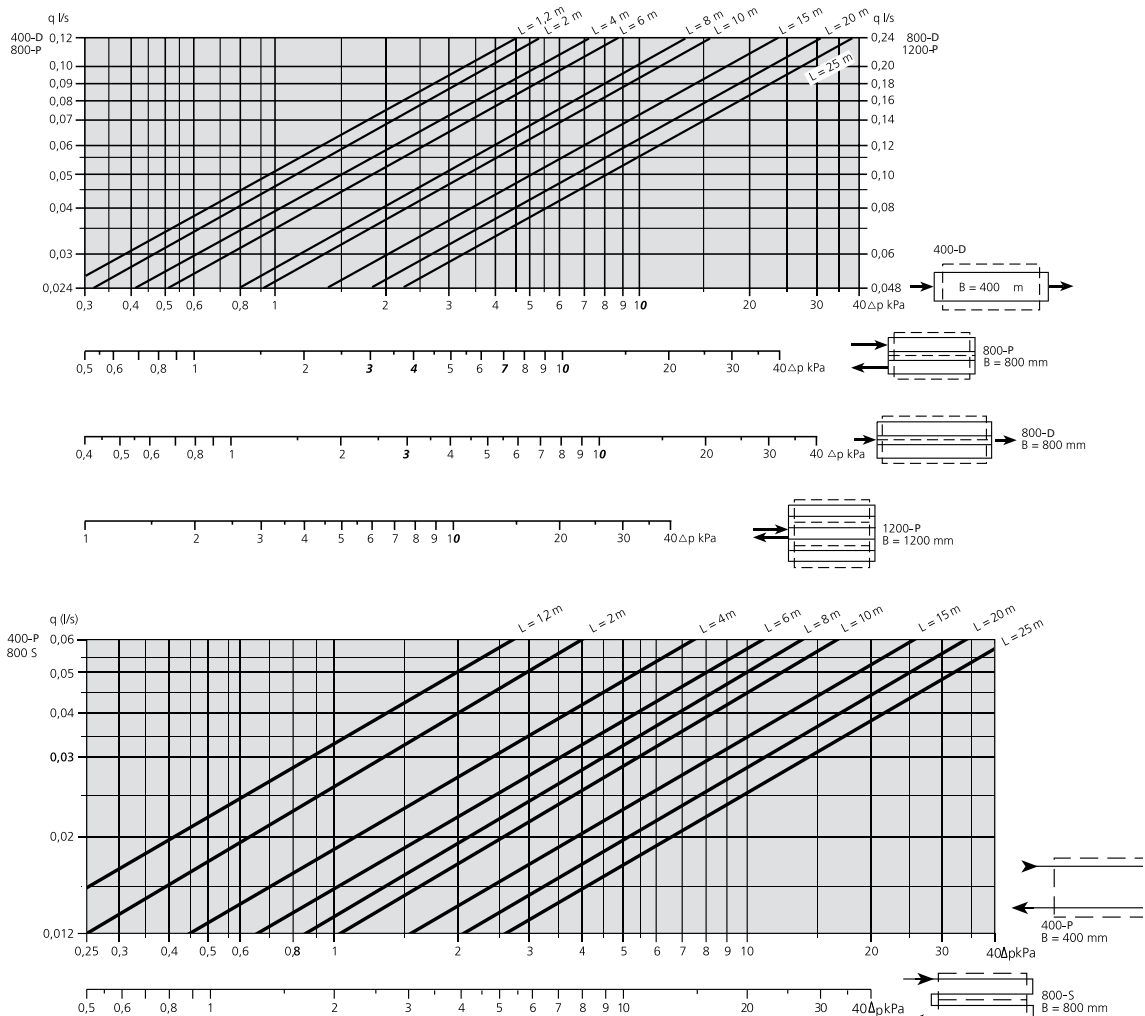

Order Catalogue

- EAL:** Water supplied radiant panel for heating or cooling.
- Length:** EAL can be made to any length in 100 mm increments from 1000 mm up to 6000 mm per panel. Several panels can be inter-connected to a maximum length of 25 m.
- Width:** 400 mm, 800 mm or 1200 mm.
- Height:** 30 mm.
- Colour:** NCS0502Y / RAL9010 (White).

Connection Water

No headers are used. Connection is made directly on smooth straight pipe ends. The following dimensions are applied:

EAL-2-P	12 mm
EAL-2-D	15 mm
EAL-4-S	12 mm
EAL-4-P / D	15 mm
EAL-6-P / S	15 mm
EAL-6-D	22 mm

Joining: Apply press fitting \varnothing 12 mm when interconnecting the panels. We recommend using products and equipment from the leading brands on the market, for the best result.

Special Modes

- Colour:** Optional colour can be delivered upon request.
- Link types:** When other link types are needed, state EAL – number of pipes – X, and specify how the panel should be linked.

Accessories

- Suspension kit:** For other suspend distance than 1000 mm. State G3SEAL + desired distance.
(G3SEAL)
- Suspension kit:** Used for surface mounting, 4 attachment points per 3000 mm length. Screw 6.5 x 100 mm and spacer are included
(G4EAL)
- Joint covers:** We carry an amount of different joint covers. Ask us about suitable solutions.

Link Types

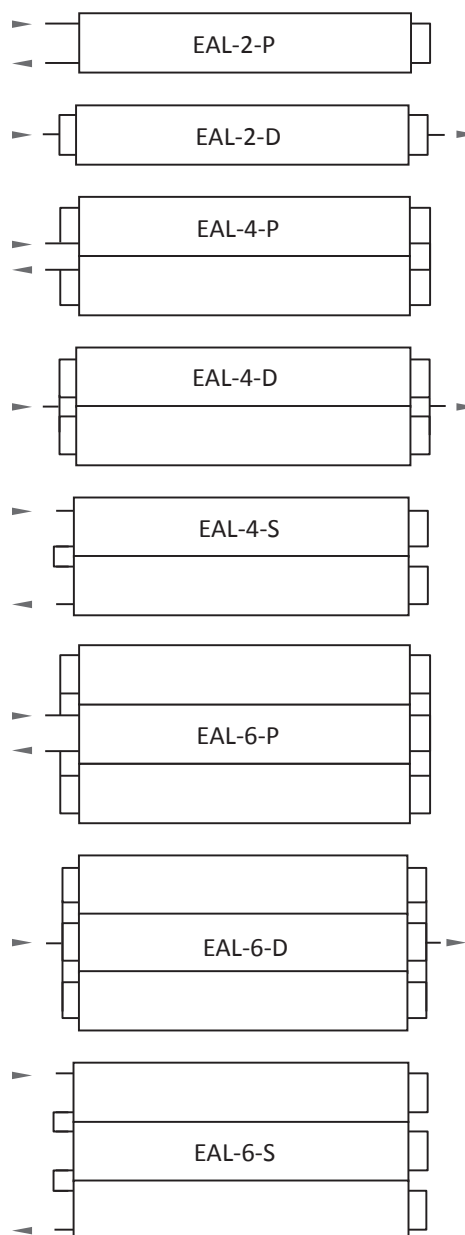

Suspension

A suspension kit (containing ceiling bracket, rod hanger with spring clip, loop screw and quadrilateral nut) is supplied with the panels by every delivery. The suspend distance ceiling/panel (rod hanger) is adjustable 500 mm to 1000 mm.

Panels longer than 2500 mm is supplied with a number of 6 units per panel. The c/c between suspension points is maximum 3000 mm.

Attachment point in/on ceiling must not be less than 20 kg. Attachment screw is not included.

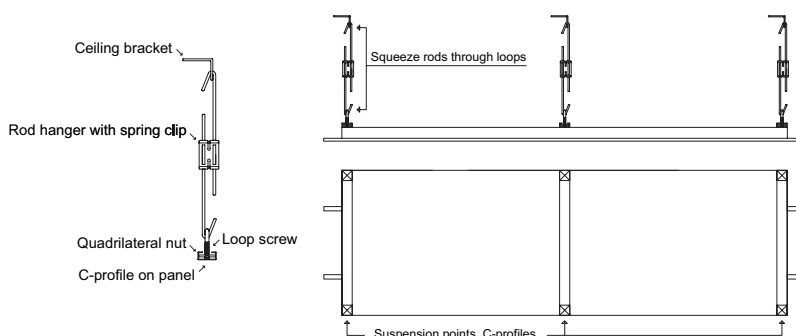

17.05.11-03EN

ENERGOTECH