

### INSTALLATION INSTRUCTION

Thank you for the purchase of our product. Please read the instruction before mounting and installing.

The device is an electronic thermostat for temperature control by means of NTC sensors, located either internally within the thermostat or externally by sensors.



### PRODUCT PROGRAM

T60-S	Multi-functional thermostat with built-in sensor and ability of two external sensors, floor and/or air. Without Wi-Fi function.
T60-SW	Multi-functional thermostat with built-in sensor and ability of two external sensors, floor and/or air. With Wi-Fi function.
ES-T60	Accessory, external floor sensor probe, NTC 10 kΩ. 3 m connection cable.



#### WARNING – Important Safety Instructions

Disconnect the power supply before carrying out any installation or maintenance work, on this thermostat and/or associated components.

The thermostat, and the associated components, should only be installed by a qualified and authorized electrician.

Electrical installation must be in accordance with appropriate national regulations.

### PLACEMENT OF THE THERMOSTAT

The thermostat should be placed on the wall, approximately 1.5 m above the floor level, when the built-in sensor is used for temperature regulation. Ensure and allow free air circulation around it. Draught and direct sunlight, or other heat sources, must be avoided. It can affect thermostat functions.

When using a floor sensor, it is strongly recommended to follow the underfloor heating supplier's advice and instructions. The sensor cable, of the accessory ES-T60, may be extended up to 50 m by means of a separate two-core cable.

### MOUNTING OF THE THERMOSTAT

The thermostat is designed to be surface mounted directly onto the wall or over an recessed junction box.

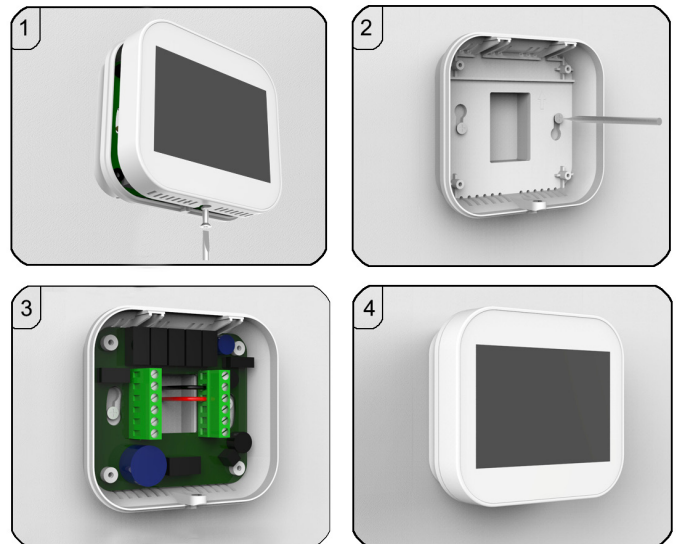

#### Step 1

Release the display by loosen the screw from the bottom of the thermostat. Then carefully pull and separate it away from the base-part, initially from the lower part of the thermostat. Keep the display in a safe place, to prevent scratches and damage.

#### Step 2

Attach and secure the base-part to the wall, or over an junction box, using 2 screws. The hole pitch, center to center, is 60 mm.

#### Step 3

Connect the wires in accordance with the diagram on page 2. The wiring diagram must be followed. If the installation wires are not coming trough the wall, the cable can be entered into the thermostat by cutting or drilling a hole on one side of the base-part.

#### Step 4

When the connection is done, refit the display carefully to the base-part, starting with the upper part of the thermostat, and gently tighten the bottom retaining screw.

The thermostats is now ready to operate.

## CONNECTIONS - WIRING

### Terminal Marking

Terminal N:	Combined connection point, for power supply and output (neutral)
Terminal L:	Power supply (live)
Terminal Load:	Output, max. 16A (3680W)
Terminal RT1:	External floor sensor (hot)
Terminal RT2:	External room/air sensor (hot)
Terminal - (minus):	Sensor connection point (cold)

### Wiring

Connect the wires in accordance with the diagram. The wires must be connected as follows:

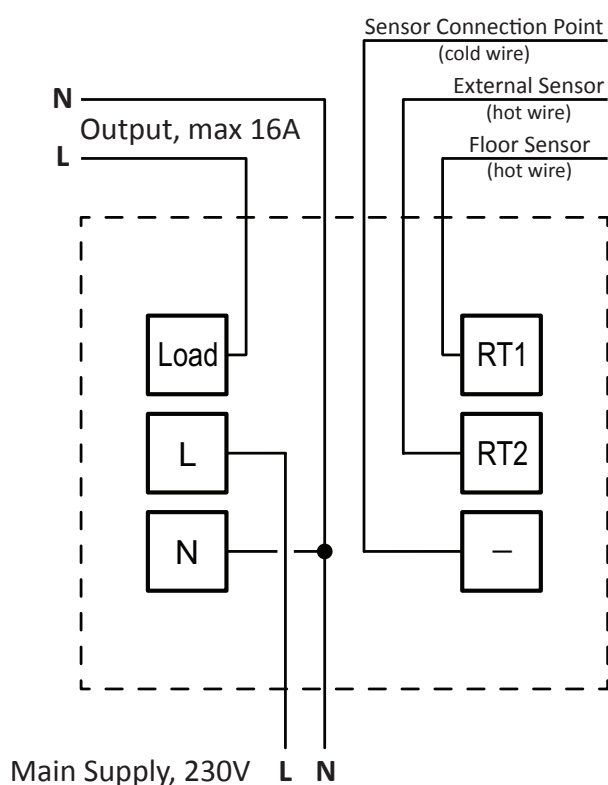

Main Supply, 230V L N

## OPERATING THE THERMOSTAT

When powering up the thermostat, it will automatically start to run in mode with the factory settings. There is no mechanical ON/OFF switch. To access this feature, simply soft tap on the touchscreen and/or the symbol 



### Programming and Setup

The thermostat carries a lot of features and settings. In order to access these points, download the user manual at <http://www.energotech.com/products/energocontrol/>. It will guide you through the setup of the different functions and modes.

## TECHNICAL SPECIFICATION

Operating voltage / Power supply	85-230VAC, 50/60Hz
Standby power	< 1.0W
Rated Current / Relay	16A resistive load, 230V
Setting range, temperature	5-45°C
Floor limitation, temperature range	20-45°C
On/Off differential	±0.5°C
Humidity sensor, air	0-100%
Operating modes	<p><b>Three programming modes:</b>                      Weekday/Weekend (5 + 2)                      - edit/set 4 time periods per day                      Seven day programming (7)                      - edit/set 4 time periods per day                      24 hours mode                      - edit/set 4 time periods</p> <p><b>Hold/Timer mode:</b>                      - activate and adjust a boost period of up to 24h, by optional setting range temperature</p> <p><b>Home/Away mode:</b>                      - the thermostat will turn on the heating, if the room temperature drops below the set value.</p> <p><b>Holiday mode:</b>                      - calendar based and programmable in advance.</p> <p><b>OFF mode:</b>                      - frost protection included, by adjustable temperature range</p>
Battery backup	2 months
Wireless standard, for T60-SW	Wi-Fi 802.11 b/g/n (2.4G)
Appliance and protection class	Class II - IP20
Size, dimensions (H/W/D)	86/96/32 mm
Installation type	Surface mount
Hole pitch (center to center)	60 mm
Terminals	2.5 mm <sup>2</sup> , screw cage clamp
Terminal wire size	max. 2.5 mm <sup>2</sup>
Display size	3.5" - Color capacitive touch
Display resolution	480x320 TFT
Optional external floor sensor	NTC (10 kΩ), Class II, 3 meter
Optional external room/air sensor	NTC (10 kΩ), Class II, 3 meter
Max. length sensor cable	50 m, 2 x 1.5 mm <sup>2</sup>
CE marking	Low Voltage Directive 2014/35/EU EMC Directive 2014/30/EU RoHS Directive 2011/65/EU



# ENERGOTECH